



because it works



PROFIT / PHOENIX

[WWW.WIWA.COM](http://WWW.WIWA.COM)

## PROFIT + PHOENIX – UNIQUELY VERSATILE FOR YOUR SUCCESS



WIWA PROFIT



WIWA PHOENIX

Trusted by tens of thousands of customers around the world and subject to continual optimisation!

The WIWA PROFIT and PHOENIX series offer versatile, high quality pump systems for almost all areas of application. The varied performance data and broad range of equipment options enable us to offer units for almost all application techniques in the wood and metalworking industries, as well as for the painting and finishing trades. Our decades of experience, continual development activities in close cooperation with paint and finishing product manufacturers and our inhouse precision manufacturing of all components have led to our success in the decorative and protective surface coating sector. The equipment in the PROFIT and PHEONIX series is available in rust and acid proof versions and therefore ideally suited to processing water based coatings. The pressure ratio can be adjusted to different conditions by replacing a small number of parts, thereby saving on additional investment. Carefully selected, premium quality materials create high durability and reduce the wear and tear of all parts that come into contact with the fluid. Minimal repair costs and downtime create satisfied customers all over the world. Robust, reliable and versatile WIWA technology to your benefit.

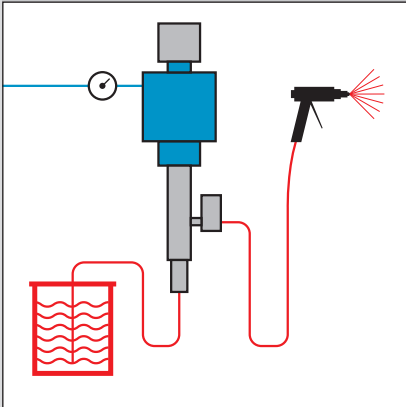

WIWA PROFIT and PHOENIX,  
Airless spraying units

## AIRLESS

High pressure

**Economical, environmentally friendly spraying method with high surface area coverage.**

The high pressure pump draws the spraying agent from any desired container and transfers it to the spray gun under high hydraulic pressure via a high pressure hose.

Fine, airless atomisation is achieved through a specially designed spray nozzle. The spray jet is directed onto the material at high speed, thereby providing an optimal finish.

### The benefits at a glance:

- Effective painting and coating of large surfaces
- Saves materials and solvent
- Higher coating thickness in just one pass
- Better use of energy due to minimal air consumption
- Closed, uniform spray pattern
- Little spray mist when correctly configured
- Explosion protected as operated by compressed air

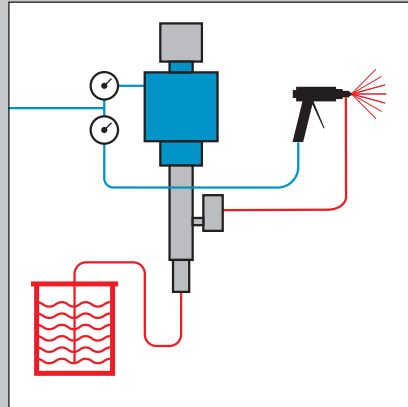

WIWA PROFIT and PHOENIX,  
Air Combi finishing systems

## AIR COMBI

Air-assisted painting

**The Air Combi combines the advantages of Airless and conventional spraying techniques.**

Using this painting method, the spraying agent is transferred to the spray gun under moderate pressure and pre-atomised. The fine spray distribution is achieved by applying regulated compressed air as the paint is discharged. A soft, controllable spray jet is produced with minimum paint mist.

Ideal for highly refined painting tasks on large surface areas as well as for angular components and shaped or small workpieces.

### The benefits at a glance:

- High material savings
- The finest atomisation generates first class finishes
- Low operating costs due to minimal air consumption
- Soft, controllable spray pattern
- Low pump wear due to low material pressure
- Environmentally friendly due to minimal overspray

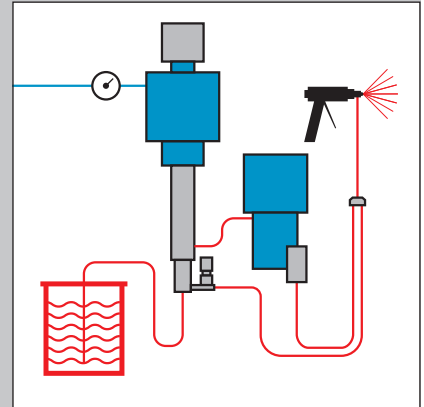

WIWA PHOENIX  
Hot Job hot spraying system

## HOT SPRAYING SYSTEMS

**The hot spraying equipment for higher film builds, shorter drying times and the finest finish quality.**

During the hot spraying process the spraying agent is heated to the desired spraying temperature using the WIWA material flow heater.

This eliminates the need to use solvents to alter the viscosity. An adjustable circulation system maintains a constant material temperature

### The benefits at a glance:

- Excellent surface coverage
- Short drying periods
- High film builds
- Even highly viscous materials can be effortlessly processed
- Environmentally and user friendly as no solvents are required
- Glossier surfaces due to improved paint dispersion

Existing Airless spraying units can be converted into the Air Combi system.

## PROFIT – AIRLESS AND AIR COMBI PAINTING EQUIPMENT



WIWA PROFIT:  
proven technology  
that meets all  
requirements for  
everyday work

The compact dimensions of the high performance units in the WIWA PROFIT series makes them ideal for flexible use by trade and industry. As all models come in both Airless and Air Combi versions, the right technology is available for nearly all areas of application. Above average durability and trouble free performance are guaranteed by the double pistons, carbide faced valve plates and stainless steel valve balls as well as a dual filter system comprising suction and high pressure filters. A closed lubrication chamber separates the air motor and the material pump. The lubricant prevents paint from drying onto the piston rod and protects the packings.

The PROFIT units with paint feed funnels are ideal for repairs and touch up work, as well as other activities in which only small material quantities should be processed. All units are available in rust and acid proof versions and therefore suitable for use with water based coatings.



All PROFIT units are fitted with a high pressure filter as standard

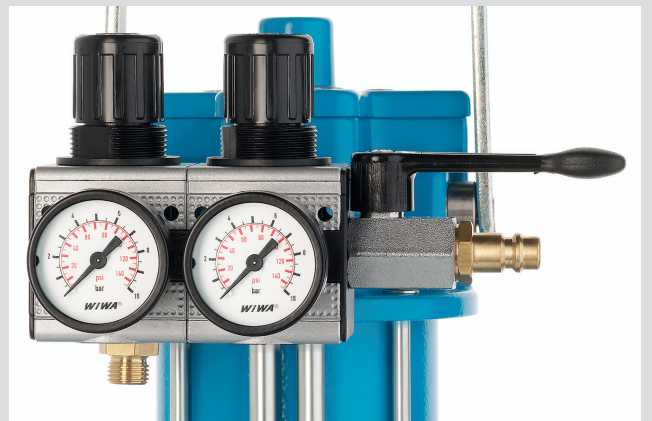

Double compressed air regulator for spray pressure and atomiser air (Air Combi)

## THE ADVANTAGES OF THE PROFIT SERIES

- Ideal for trade and industry.
- Portable for flexible use anywhere.
- Pulsation is barely noticeable thanks to the high stroke changeover speed.
- Spring supported, self adjusting packings reduce wear and tear.
- Heavy duty housing and a new seal system further improve safety.
- Quicker and simpler maintenance and assembly thanks to direct threading and wrench flats.
- As Airless spraying unit: robust and handy for efficient painting and coating.
- As Air Combi finishing system for top quality, even finishes.



# PROFIT

# PROFIT – CONFIGURATION OPTIONS

Technical data												
Model	3010		3022		3033		4210		4222		4233	
Max. output	3.0 l/min		3.0 l/min		3.0 l/min		4.2 l/min		4.2 l/min		4.2 l/min	
Pressure ratio	10:1		22:1		33:1		10:1		22:1		33:1	
Pump capacity per double stroke	14 cm <sup>3</sup>		14 cm <sup>3</sup>		14 cm <sup>3</sup>		27 cm <sup>3</sup>		27 cm <sup>3</sup>		27 cm <sup>3</sup>	
Max. air inlet pressure	8 bar		8 bar		8 bar		8 bar		8 bar		8 bar	
Max. operating pressure	80 bar		176 bar		264 bar		80 bar		176 bar		264 bar	
Piston diameter of the air motor	50 mm		70 mm		85 mm		50 mm		70 mm		85 mm	
Piston stroke of the air motor	42 mm		42 mm		42 mm		75 mm		75 mm		75 mm	
Version	N	RS	N	RS	N	RS	N	RS	N	RS	N	RS
PROFIT Airless spraying unit <sup>1,2</sup>												
With pail <sup>5</sup>	0644260	0644261	0644270	0644271	0644280	0644281	0644290	0644291	0644300	0644301	0644310	0644311
With tripod	0644262	0644263	0644272	0644273	0644282	0644283	0644292	0644293	0644302	0644303	0644312	0644313
On cart	0644264	0644265	0644274	0644275	0644284	0644285	0644294	0644295	0644304	0644305	0644314	0644315
With feed funnel	0644266	0644267	0644276	0644277	0644286	0644287	0644296	0644297	0644306	0644307	0644316	0644317
On wall bracket	0644268	0644269	0644278	0644279	0644288	0644289	0644298	0644299	0644308	0644309	0644318	0644319
PROFIT Air Combi finishing systems <sup>3,4</sup>												
With pail <sup>5</sup>	0644320	0644321	0644330	0644331	0644340	0644341	0644350	0644351	0644360	0644361	0644370	0644371
With tripod	0644322	0644323	0644332	0644333	0644342	0644343	0644352	0644353	0644362	0644363	0644372	0644373
On cart	0644324	0644325	0644334	0644335	0644344	0644345	0644354	0644355	0644364	0644365	0644374	0644375
With feed funnel	0644326	0644327	0644336	0644337	0644346	0644347	0644356	0644357	0644366	0644367	0644376	0644377
On wall bracket	0644328	0644329	0644338	0644339	0644348	0644349	0644358	0644359	0644368	0644369	0644378	0644379

N = Carbon steel version  
 R = Stainless steel version  
 RS = Rust and acid proof version

#### 1 Spray accessory kit no. 01 N + R

- Order no. 0621625 comprising:
- WIWA 250 D Airless spray gun (with swivel joint)
  - NW6 material hose (1/4"), 410 bar, 7.5 m
  - Standard nozzle 40° – 0.33 mm

#### 2 Spray accessory kit no. 10 RS

- Order no. 0629957 comprising:
- WIWA 500 F Airless spray gun (with swivel joint)
  - (RS) NW6 material hose (1/4"), 410 bar, 7.5 m
  - Standard nozzle 65° – 0.33 mm

#### 3 Air Combi spray gun

Order-no. 0653095,  
 Nozzle included.

#### 4 WIWA PROFIT Air Combi

All Air Combi paint spraying units come with an NW6 air and material hose

#### 5 WIWA PROFIT pail

The pail designs are only available in N = mild steel version and R = stainless steel versions.



1



2



3



4



5



6

1 WIWA PROFIT with pail

2 WIWA PROFIT with tripod

3 WIWA PROFIT with feed funnel

4 WIWA PROFIT with wall bracket

5 WIWA PROFIT on cart

6 WIWA PROFIT RS-1 (brochure on request)

## DESIGN FEATURES OF THE PROFIT SERIES

### Air motor

- 1 Pulsation is barely noticeable thanks to the high stroke changeover speed.
- 2 Low number of components make the motor easy to assemble and disassemble.
- 3 Pressure ratio can be varied by changing the air motor piston diameter.

### Lubrication chamber

- 4 A closed lubrication chamber separates the air motor and the material pump. The closed design prevents foreign objects such as blasting material from entering the pump system from the outside. The lubricant also prevents paint from drying onto the piston rod and protects the packings.

### Material pump

Less pressure loss even with highly viscous materials due to large bores and voluminous material passages in the bottom valve.

- 5 Precision guides ensure simple and exact alignment of components and thus less wear and tear.
- 6 Better flushing due to short packing retention springs and large fluid passages.
- 7 Sealing rings located in front of the threads prevent the threads from sticking and make disassembly easier.
- 8 Pump components are quick to assemble and disassemble as they are simply screwed together.

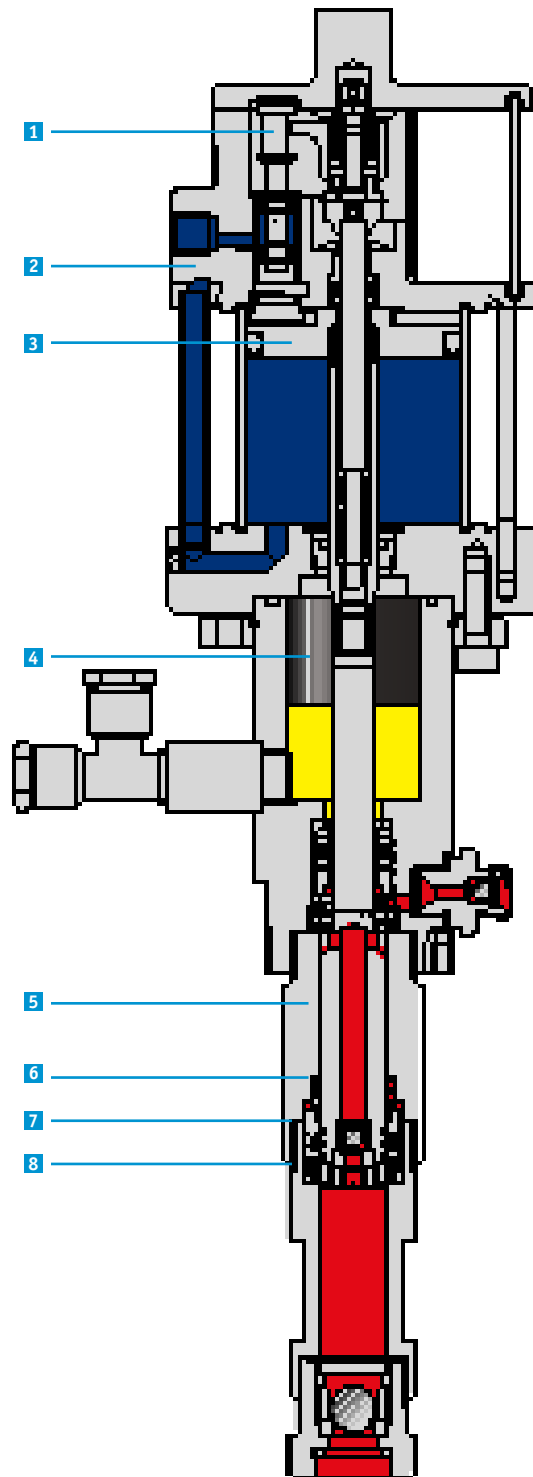

PROFIT

The WIWA modular system  
meets all your requirements!

## PROFIT – AREAS OF APPLICATION



We recommend	PROFIT Airless paint spraying units				PROFIT Air Combi finishing units					
Model	3022	3033	4222	4233	3010	3022	3033	4210	4222	4233
Max. output	3.0 l/min	3.0 l/min	4.2 l/min	4.2 l/min	3.0 l/min	3.0 l/min	3.0 l/min	4.2 l/min	4.2 l/min	4.2 l/min
Pressure ratio	22:1	33:1	22:1	33:1	10:1	22:1	33:1	10:1	22:1	33:1
Pump capacity per double stroke	14 cm <sup>3</sup>	14 cm <sup>3</sup>	27 cm <sup>3</sup>	27 cm <sup>3</sup>	14 cm <sup>3</sup>	14 cm <sup>3</sup>	14 cm <sup>3</sup>	27 cm <sup>3</sup>	27 cm <sup>3</sup>	27 cm <sup>3</sup>
<b>Areas of application</b>										
Carpentry shops	●	●	●	●	●	●	●	●	●	●
Furniture industry	○	○	●	●	○	○	○	○	○	●
Paint and finishing shops	–	–	○	○	–	–	–	○	○	●
Machine/automotive construction	–	–	–	○	–	–	–	○	○	○
<b>Spraying agent</b>										
Oil and grease	○	●	○	●	○	●	●	○	●	●
Thick-coat varnish	–	●	–	●	●	●	●	●	●	●
Primer	○	●	●	●	●	●	●	●	●	●
Sprayable spackle	–	○	–	○	–	–	–	–	–	–
Sprayable paints and varnishes	●	●	●	●	●	●	●	●	●	●
Two component material	○	○	○	○	–	○	○	–	○	○
Textured paint	–	●	–	●	●	●	●	●	●	●
Hammertone paint	–	●	○	●	●	●	●	●	●	●
Water soluble materials	○	●	○	●	●	●	●	●	●	●
Water based paints	○	○	○	●	●	●	●	●	●	●

● Very suitable ○ Suitable – Unsuitable

Existing Airless spraying units can be converted into Air Combi systems.



## THE AREAS OF APPLICATION OF THE PROFIT SERIES

- Carpentry shops
- Furniture industry
- Paint and finishing shops
- Machine and automotive construction

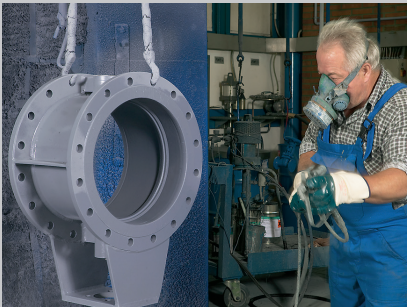

# PROFIT

## PHOENIX – AIRLESS, AIR COMBI AND HOT JOB HOT SPRAYING U



Above-average durability is a must for efficient use.

Like all other WIWA equipment series, the WIWA PHOENIX series impresses through the above average durability of all its components. Carefully selected, high quality materials reduce wear and tear during daily operation and keep repair costs to a minimum. If the usage conditions change, the pressure ratio and output can be easily adjusted by replacing a small number of components, thus avoiding additional investments.

The PHOENIX series is uniquely versatile thanks to its sophisticated design.

The units, which are made from few components, can be quickly and modularly assembled and converted for various areas of application. All units are available in rust and acid proof versions and therefore ideally suited for use with water based coatings. Thanks to the high pressure ratio, the PHOENIX 6552 can also be used to process highly viscous coating materials. The PHOENIX 6552 with feed funnel is particularly suited for repair work in relation to corrosion protection in which only small material quantities need to be used, e.g. touch up work on construction sites, repairs and coatings on and under ship decks on the high seas, as well as for laboratory work with highly viscous materials in the paint industry.

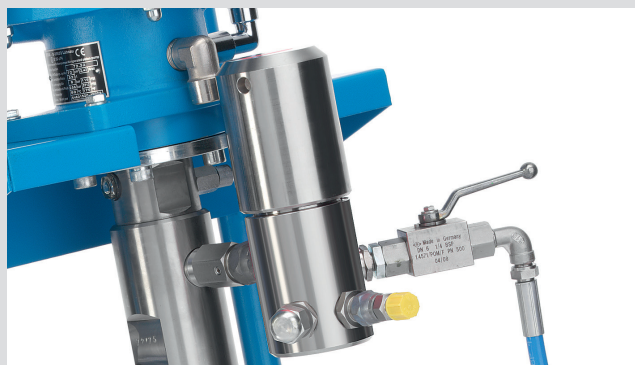

All PHOENIX units are fitted with a high pressure filter as standard



All Phoenix units are supplied with a maintenance unit as standard

# NITS FOR TRADE AND INDUSTRY

## THE ADVANTAGES OF THE PHOENIX SERIES

- Fixed, self adjusting packings.
- Dual action pump with a long stroke.
- Maintenance free, low noise compressed air engine.
- Thorough cleaning through an innovative flushing system.
- A closed lubrication chamber separates the air motor and the material pump. The lubricant prevents fluids from drying onto the piston rod and protects the packings.
- Large valve and material passages make processing highly viscous materials simple.
- Self adjusting packings reduce wear and tear and lower maintenance costs.
- Above average service life due to hard chromed dual pistons, carbide faced valve plates and stainless steel valve balls.
- Dual filter system prevents downtime.
- Generously sized air ducts and a new control system guarantee a rapid changeover of the air motor, practically eliminating any pulsation of the spray jet and the freezing of the air motor.
- Efficient use through the simultaneous operation of multiple spray guns, depending on the nozzle size used.
- Environmentally friendly thanks to noise levels being kept to a minimum by the optimised control system and the large built in muffler.



# PHOENIX

# PHOENIX – CONFIGURATION OPTIONS

Technical data												
Model	6530			6552			11018			11032		
Max. output	6.5 l/min			6.5 l/min			11 l/min			11 l/min		
Pressure ratio	30:1			52:1			18:1			32:1		
Pump capacity per double stroke	40 cm <sup>3</sup>			40 cm <sup>3</sup>			72 cm <sup>3</sup>			72 cm <sup>3</sup>		
Max. air inlet pressure	8 bar			8 bar			8 bar			8 bar		
Max. permissible operating pressure	240 bar			416 bar			144 bar			256 bar		
Piston diameter of the air motor	105 mm			140 mm			105 mm			140 mm		
Piston stroke of the air motor	75 mm			75 mm			75 mm			75 mm		
Version	N	R	RS	N	R	RS	N	R	RS	N	R	RS
PHOENIX Airless spraying units												
On cart	0641351	0641352	0641353	0641357	0641358	0641359	0641363	0641364	0641365	0641369	0641370	0641371
On wall bracket	0641354	0641355	0641356	0641360	0641361	0641362	0641366	0641367	0641368	0641372	0641373	0641374
With feed funnel	0642126	–	–	0642137	0642138	–	–	–	–	–	–	–
Spray accessory set	0642474	0642474	0629957	0642476	0642476	0629957	0642474	0642474	0629957	0642475	0642475	0629957
PHOENIX Air Combi finishing systems												
On cart	0641379	0641380	0641381	–	–	–	0641391	0641392	0641393	0641397	0641398	0641399
On wall bracket	0641382	0641383	0641384	–	–	–	0641394	0641395	0641396	0641400	0641401	0641402
Spray gun (max. 250 bar) with nozzle	0653095	0653095	0653095	0653095	0653095	0653095	0653095	0653095	0653095	0653095	0653095	0653095
PHOENIX Hot Job hot spraying systems												
On cart	0641497	0641498	0641499	0641385	0641386	0641387	0641503	0641504	0641505	0641509	0641510	0641511
On wall bracket	0641500	0641501	0641502	0641388	0641389	0641390	0641506	0641507	0641508	0641512	0641513	0641514
Spray accessory set	0642477	0642477	0642478	0642477	0642477	0642478	0642477	0642477	0642478	0642477	0642477	0642478

N = Mild steel version R = Stainless steel version RS = Rust and acid proof version

#### Spray accessory set no. 13

Order no. 0642474, comprising:

- WIWA 250 D spray gun (with swivel joint)
- NW 6 material hose (410 bar, 1/4", 7.5 m)
- Standard nozzle 40° – 0.38 mm

#### Spray accessory set no. 16

Order no. 0642477, comprising:

- WIWA 500 F Airless spray gun (with swivel joint)
- 2x NW 6 material hose (410 bar, 7.5 m)
- 1x NW 4 (410 bar, 1 m)
- Return manifold 3x 1/4"
- Standard nozzle 65° – 0.53 mm

#### Spray accessory set no. 14

Order no. 0642475, comprising:

- WIWA 500 D Airless spray gun (with swivel joint)
- NW 6 material hose (410 bar, 1/4", 7.5 m)
- Reversible guard REV-GUARD™
- Nozzle 621

#### Spray accessory set no. 10 RS

Order no. 0629957, comprising:

- WIWA 500 F Airless spray gun (with swivel joint)
- NW 6 material hose (410 bar, 1/4", 7.5 m)
- Standard nozzle 65° – 0.33 mm

#### Spray accessory set no. 15

Order no. 0642476, comprising:

- WIWA 500 D Airless spray gun (with swivel joint)
- NW 6 material hose (600 bar, 1/4", 7.5 m)
- Reversible guard REV-GUARD™
- Nozzle 621

#### Spray accessory set no. 17 RS

Order no. 0642478, comprising:

- WIWA 500 F Airless spray gun (with swivel joint)
- 2x NW 6 material hose (410 bar, 7.5 m)
- 1x NW 4 (410 bar, 1 m)
- Return manifold 3x 1/4" -RS-
- Standard nozzle 65° – 0.38 mm



1 WIWA PHOENIX on cart

2 WIWA PHOENIX with feed drum

3 WIWA PHOENIX with wall bracket

4 WIWA PHOENIX Hot Job hot spraying unit

## DESIGN FEATURES OF THE PHOENIX SERIES

### Air motor:

- 1 Low number of components make the motor easy to assemble and disassemble.
- 2 The toggles are clearly visible and thus easy to install.
- 3 Pulsation is barely noticeable thanks to the high stroke changeover speed.
- 4 Output can be varied by changing the air motor piston diameter.

### Lubrication chamber

- 5 A closed lubrication chamber separates the air motor and the material pump. The closed design prevents foreign objects such as blasting material from entering the pump system from the outside. The lubricant also prevents paint from drying onto the piston rod and protects the packings.

### Material pump:

- 6 Pump components are quick to assemble and disassemble as they are simply screwed together. During disassembly, the parts are automatically separated.
- 7 Sealing rings located in front of the threads prevent the threads from sticking and make disassembly easier.
- 8 Precision guides ensure simple and exact alignment of components and thus less wear and tear.
- 9 Large openings and voluminous fluid passages reduce pressure loss.
- 10 Better flushing due to large fluid passages and short packing retention springs.
- 11 The displacement and pressure ratio can be changed by exchanging the piston rod and packings.

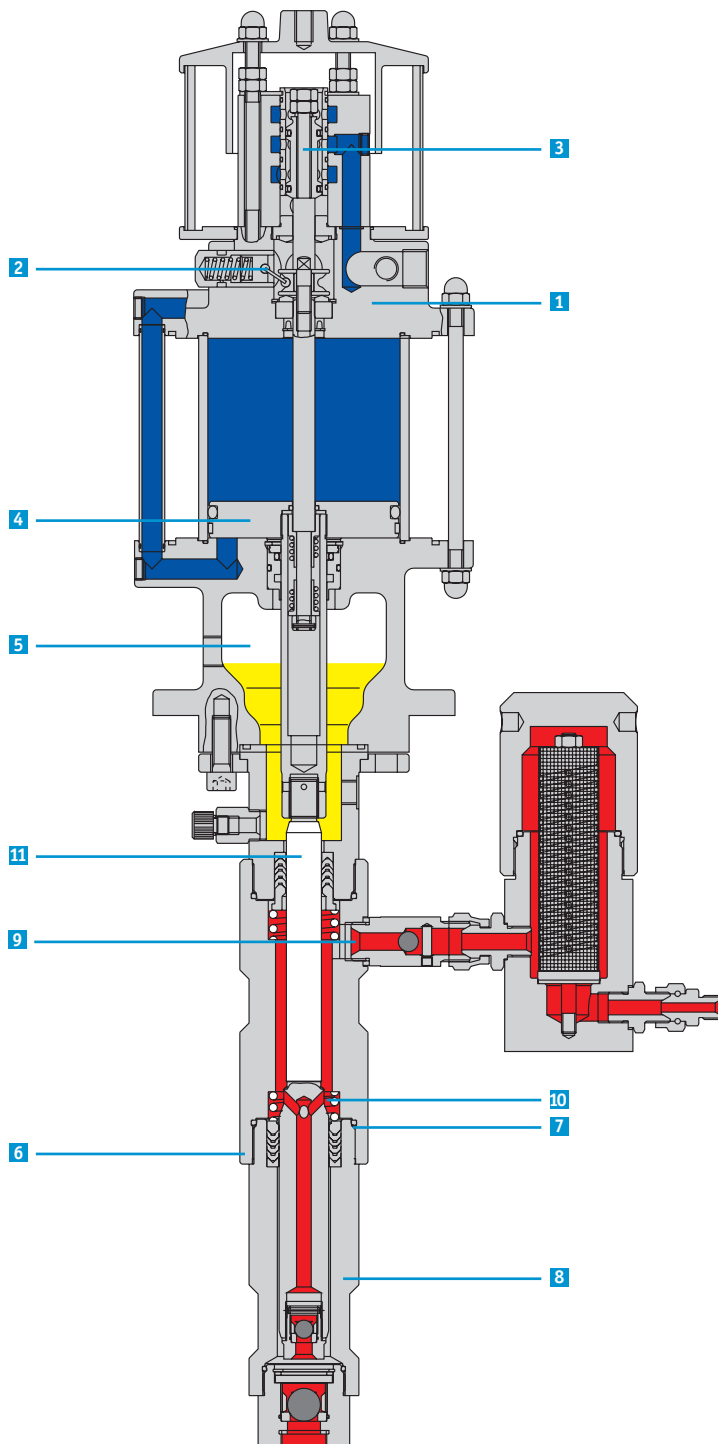

# PHOENIX

# PHOENIX – AREAS OF APPLICATION



We recommend	PHOENIX Airless paint spraying units				PHOENIX Air Combi finishing systems			PHOENIX Hot Job hot spraying systems			
	6530	6552	11018	11032	6530	11018	11032	6530	6552	11018	11032
Model	6530	6552	11018	11032	6530	11018	11032	6530	6552	11018	11032
Max. output	6.5 l/min	6.5 l/min	11 l/min	11 l/min	6.5 l/min	11 l/min	11 l/min	6.5 l/min	6.5 l/min	11 l/min	11 l/min
Pressure ratio	30:1	52:1	18:1	32:1	30:1	18:1	32:1	30:1	52:1	18:1	32:1
Pump capacity per double stroke	40 cm <sup>3</sup>	40 cm <sup>3</sup>	72 cm <sup>3</sup>	72 cm <sup>3</sup>	40 cm <sup>3</sup>	72 cm <sup>3</sup>	72 cm <sup>3</sup>	40 cm <sup>3</sup>	40 cm <sup>3</sup>	72 cm <sup>3</sup>	72 cm <sup>3</sup>
<b>Areas of application</b>											
Carpentry shops	●	○	●	●	●	●	●	●	●	●	●
Furniture industry	●	○	●	●	●	●	●	●	●	●	●
Paint and finishing shops	○	○	○	●	●	●	●	–	●	○	●
Machine and automotive construction	–	–	○	–	●	●	●	–	–	●	–
Steel and hall construction	○	○	○	○	–	–	●	–	○	–	○
Steelworking industry	○	○	○	○	○	○	○	○	○	○	○
Automatic/manual coating systems	○	○	–	○	○	○	○	○	○	–	○
Shipbuilding (interior painting)	○	○	–	○	○	○	○	○	○	–	○
Railcar construction	○	○	–	○	○	○	○	○	○	–	○
Transfer pumps	–	–	●	●	–	–	–	–	–	■	–
<b>Spritzgut</b>											
Primer	●	–	○	●	●	●	●	○	○	○	○
Sprayable spackle	●	●	–	●	–	–	–	○	○	–	○
Sprayable paints and varnishes	●	●	○	●	●	●	●	●	●	○	●
Two component and tar/epoxy paints*	●	●	–	●	●	●	●	○	●	○	○
Textured paint	●	●	–	●	●	●	●	○	○	–	○
Hammer tone paint	●	●	–	●	●	●	●	○	○	–	○
Zinc coatings	–	–	–	○	–	–	–	○	○	○	○
Rust protective/micaceous iron oxide paints	●	●	–	●	○	○	○	○	○	–	○
Low solvent and solvent free paints	–	○	–	–	–	–	–	○	○	○	○
Stains	–	–	●	–	–	–	–	–	○	–	–
Water based paints	●RS	–	–	●RS	●RS	●RS	●RS	–	–	–	–
Clear coat paints	●	–	–	●	●	●	●	○	–	–	○
Thick coat varnishes	●	○	–	●	●	●	●	○	○	–	○

● Very suitable ○ Suitable – Unsuitable

Existing Airless spraying units can be converted into Air Combi or hot spraying systems

## THE AREAS OF APPLICATION OF THE PHOENIX SERIES

- Carpentry shops
- Furniture industry
- Paint and finishing shops
- Machine and automotive construction
- Steel and hall construction
- Steelworking industry
- Automatic or manual finishing systems
- Ship painting (interior painting) and repair work on the high seas
- Railcar construction

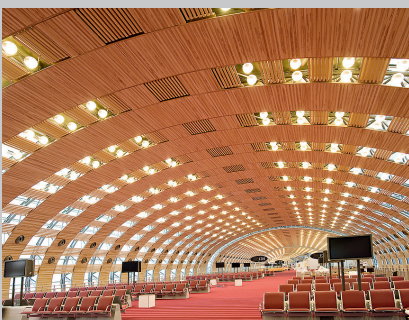

# PHOENIX

**PRODUCT RANGE EXAMPLES****ATEX 94/9/EG****Headquarters and Production**

WIWA Wilhelm Wagner GmbH & Co. KG  
35633 Lahnuau, Germany  
Phone: +49 (0) 6441 609-0

[www.wiwa.com](http://www.wiwa.com)

**WIWA Subsidiary USA**

WIWA LLC – USA, Canada, Latin America  
107 N. Main St.  
P.O. Box 398, Alger, OH 45812  
Tel.: +1-419-757-0141  
Fax: +1-419-549-5173  
Toll-Free: +1-855-757-0141

[www.wiwausa.com](http://www.wiwausa.com)

WIWA (Taicang) Co., Ltd.  
Taicang City  
Jiangsu Province 215400, P.R.China  
Phone: +86-512-53548857

[www.wiwa-china.com](http://www.wiwa-china.com)

**WIWA Middle East General Trading LLC**  
Jebel Ali Industrial 1  
DUBAI, United Arab Emirates  
Phone: +9714-884-8220

[www.wiwa-middleeast.com](http://www.wiwa-middleeast.com)



WIWA FLEXIMIX Electronic 2K  
Paint Spraying and Coating Equipment



WIWA Fluid Transfer Pumps  
for diverse applications



WIWA DUOMIX Plural Component Airless  
Paint Spraying Equipment



WIWA Airless, Air-Combi  
and Hot Spraying Systems

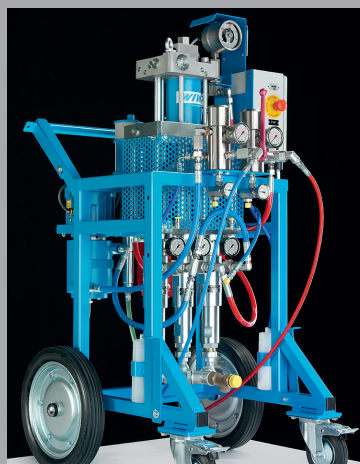

WIWA POWERPACK XXL 2K  
Hydraulic Systems



WIWA PU 460  
Polyurea Systems