

## MOTORS WITH POWER OVER 1000 W

NK SERIES - Non reversible

WATT: 3100 / Consumption: 2800 NI/1"

DATA SHEET  
NK1900S

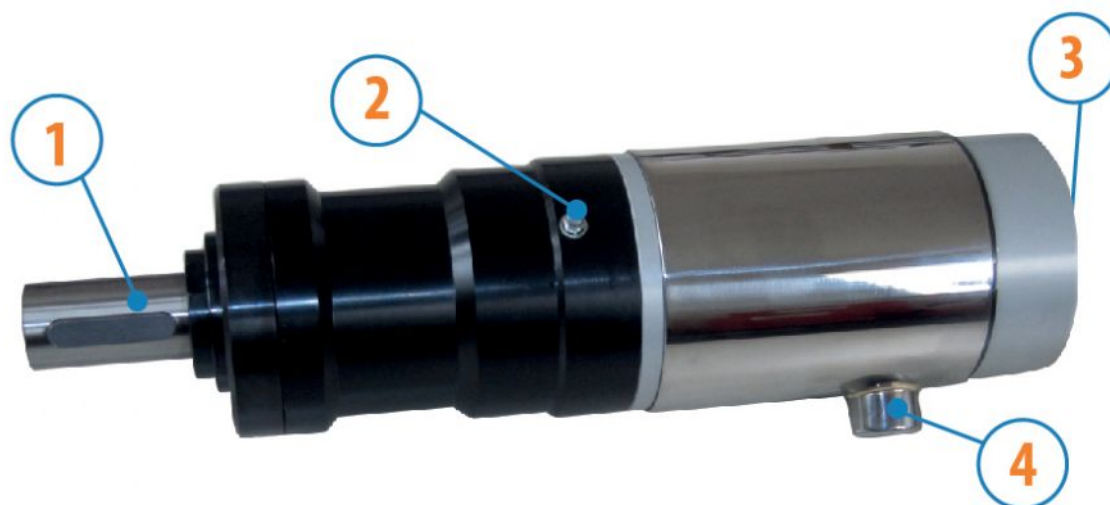

1. Cylindrical keyed shaft
2. Grease gun
3. Air inlet
4. Air exhaust

### Technical sheet

Left rotation - Model	NK1900S
Left rotation - Code	8721263
Speed rpm - No-load	1850
Speed rpm - at Max Power	1350
Torque Nm - at Max Power	22
Torque Nm - Stall Torque	53

### CHARACTERISTICS OF SHAPE

The normal delivery condition:  
cylindrical shaft and body as shown in the photo.

Optional:

Shaft

- threaded - indication / AF (left rotation excluded - subject to checks for reversible)

- conical - indication / AC

- with collets - indication / AP

### PERFORMANCE FIGURES

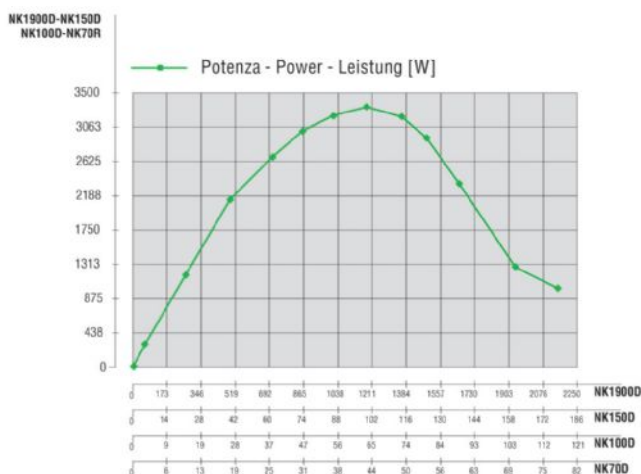
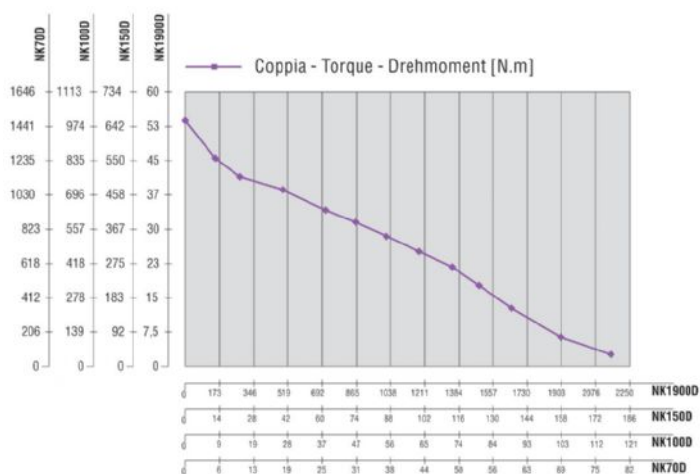

## MOTORS WITH POWER OVER 1000 W

NK SERIES - Non reversible

WATT: 3100 / Consumption: 2800 NI/1"

## DATA SHEET

### NK1900S

### RADIAL AND AXIAL LOADS

Model	Code	Fr (N)	Fa (N)	Co (N)
NK1900S	8721263	11000	8000	54000

### OVERALL DIMENSIONS

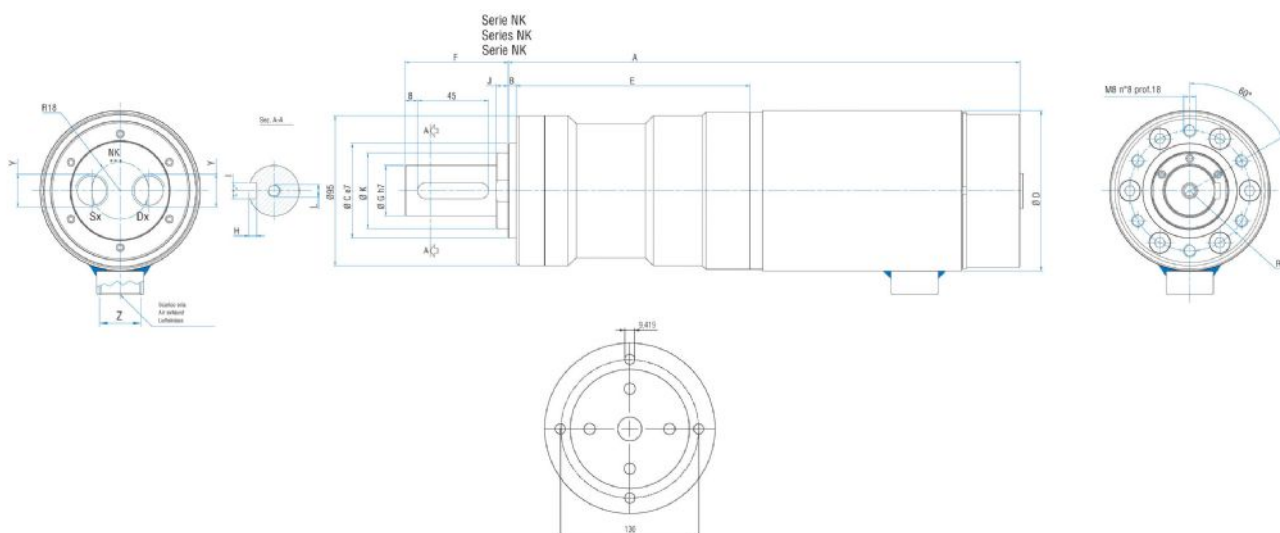

Flange disponibili per alcuni modelli.  
 Flanges available for some models.  
 Flansche erhältlich für einige Modelle.

Model	Code	A	B C	D	E	F	G	H	I	J	K	L	Y	Z
NK1900S	8721263	331,8	5 60	101,6	148,3	65,5	32	5	10	7,5	48	M8	1/2"	3/4"